

# Solatube® SkyVault™ Series

## Solatube® M74 DS Daylighting Dimmer

### Installation Instructions

Parts List		Quantity
1	Tube Belt	(1)
2	12 in (305 mm) Transition Tube	(2)
3	Daylight Dimmer	(1)
4	Daylight Dimmer Screw and Fastener Kit	
	a. Tube Rivets	(12)
	b. Foil Tape 2in (50 mm) 18ft (5.5m)	(1)
5	Installation Retainer Clip	(1)
6	Daylight Dimmer Junction Box with Strain Relief (2) Pre-Installed	(1)
7	Daylight Dimmer Screw and Fastener Kit	
	a. Junction Box Mounting Screw #12 X 1/2 in (12 mm)	(3)
	b. Nylon Spacer	(1)
8	UL Listed Class 2 Transformer 24VAC, Rated 96VA, or 24VAC, Rated 20VA *Sold Separately by Solatube Int. or Equivalent Sourced Locally <b>Note: Read all Instructions to Choose Appropriate Transformer.</b>	(1)

#### Additional Materials and Tools

1	Screw Gun with Phillips #2 Screw Drive Bit
2	Precision Screwdrivers Slotted 2.5M & 1.8M
3	Rivet Gun
4	Junction Box 4 in (100 mm) X 4 in (100 mm) X 1-1/2 (38 mm) with Ground Bonding Screw. <b>Note: Required for Transformer Mounting and Connection.</b>

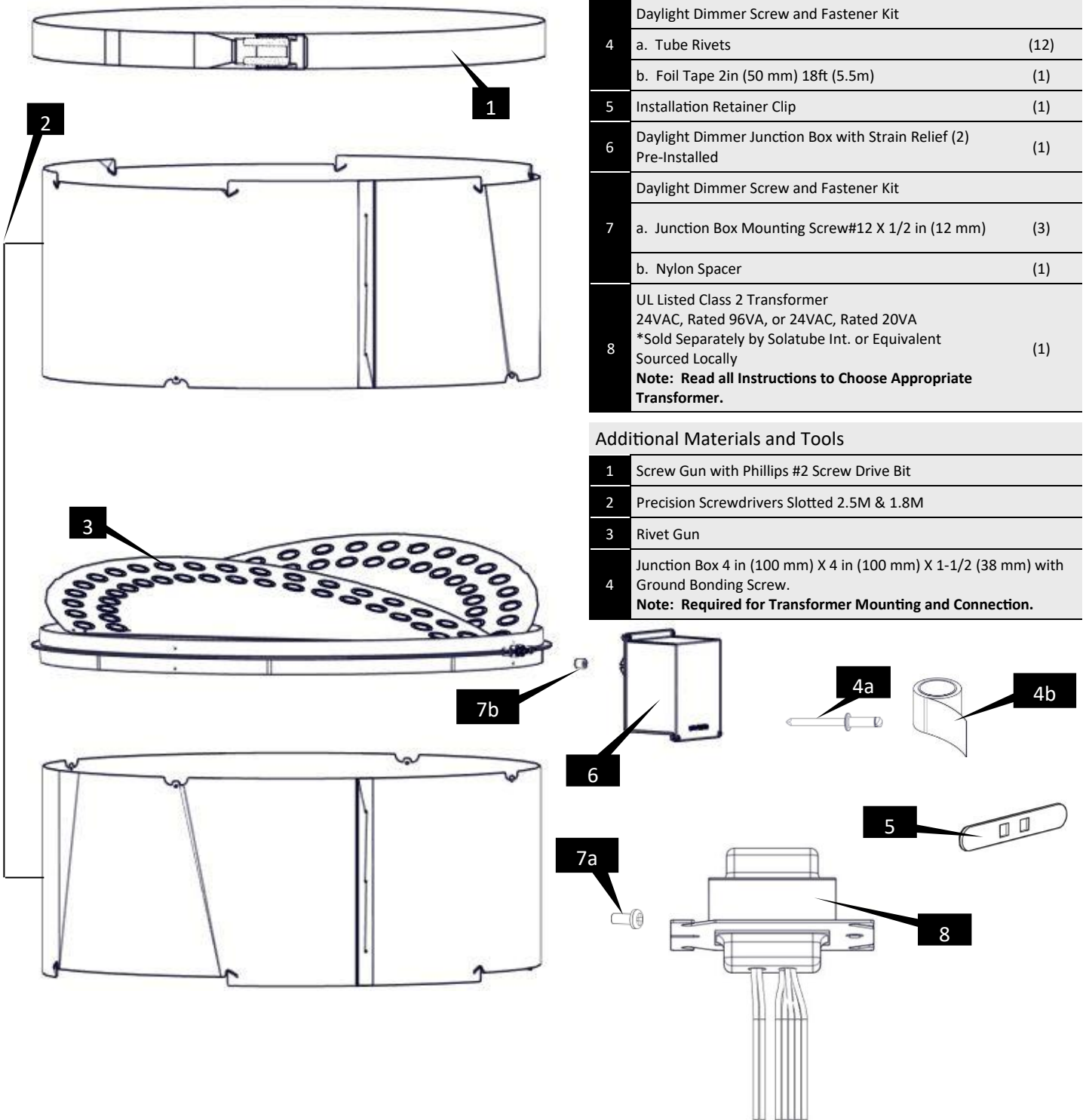

# **WARNING**



**Do not proceed with the installation until you have read the entire instructions, including these warnings. (Use of materials or methods not authorized by Solatube International will result in an invalid warranty.)**

Solatube International, Inc. (seller) assumes no responsibility or obligation whatsoever for the failure of an architect, contractor, installer, or building owner to comply with all applicable laws, ordinances, building codes, electrical codes, energy codes, fire and safety codes and requirements, roof warranties and adequate safety precautions. Installation of this product should be attempted only by individuals skilled in the use of the tools and equipment necessary for installation. Protect yourself and all persons and property during installation. If you have any doubt concerning your competence or expertise, consult a qualified expert before proceeding.



## **Install at your own risk!**

Solatube product installations may be dangerous and include the potential for death, personal injury and property damage. The hazardous conditions include but are not limited to the following:

- **During installation, the Solatube Daylighting System's reflective tubes may focus sunlight, causing intense heat or fire. Remove protective film only after the parts have been installed. Prior to and during installation, do not leave tubes in contact with combustible materials or unattended, especially near direct sunlight. Avoid skin burns.**
- Solatube Daylighting System and Solar Star products may have sharp edges. Always wear leather or canvas gloves while handling and installing products.
- Solatube product installations require climbing and working at dangerous heights, including on ladders, scaffolding, roofs and in attic spaces. Risk of death, personal injury and property damage may result from a fall, or from falling objects. Use extreme caution to minimize risk of accidental injury, including, but not limited to the following procedures:
  - Clear area below your work space of all people, animals and other items.
  - Avoid working on surfaces that are slippery or wet.
  - Use foot-wear with excellent traction.
  - Use only strong, well supported ladders.
  - Work only in calm dry weather.
  - When in the attic, ensure that your weight is supported at all times with structurally sound framing; drywall material is not designed to carry a person's weight.
- To reduce the risk of fire, electric shock, and personal injury, basic safety precautions should always be followed when using electric tools, including always wearing safety goggles or other suitable eye protection, and ensuring work area is clear of all electrical wires, gas pipes, water pipes, and other obstacles.
- When working in the attic or other dusty areas, use of a mask or respirator is recommended to avoid lung irritation. Attic spaces may be dark, confined, and subject to extreme temperatures. Beware of sharp protruding objects. Do not attempt installation without having someone within range of your voice or close enough to come to your aid if necessary.
- Solatube products are not designed to withstand the weight of a person, tools or other objects. Walking or placing objects on the system could cause personal injury and property damage. If the product is damaged, the structural capacity may be weakened; therefore the system should be repaired immediately. For safe installation and use, do not deviate from these installation instructions.
- Additional support is recommended for long vertical and all horizontal tube runs. Review local building requirements and consult with appropriate building code official for proper material and placement of additional support. Avoid galvanic reaction (corrosion) if dissimilar metals are used.

## **Electrical Components**

- Before installing, servicing, or cleaning unit, switch power off at service panel and lock service panel to prevent power from becoming switched on accidentally. When the service disconnecting means cannot be locked, securely fasten a prominent warning device such as a tag to the service panel.

## **Re-Roofing**

- Solatube products require special care if removed for re-roofing. In order to ensure proper removal and re-installation, please contact your Solatube International representative.

**Please refer to the installation tips for the appropriate product below:**



## **Daylighting Systems Installation Tips**

These instructions are a step-by-step guide for the installation of a Solatube Daylighting System in the following conditions. For other roof types, please contact your Solatube International representative for additional information.

**Built Up Flat Roof - Single Ply/Membrane - Asphalt Shingle - Low/No Pitched - Pitched - Prefabricated Curbs - Metal Roof Panels**

For the most current Installation Instructions, please visit [www.solatube.com/instructions](http://www.solatube.com/instructions)

Solatube International, Inc. | 2210 Oak Ridge Way | Vista, CA 92081-8341 | [www.solatube.com](http://www.solatube.com) | T: 888.SOLATUBE



## Daylighting Systems Installation Tips (Continued)

- Allow 1/2 hour (30 min) for the installation excluding curb fabrication, particularly if this is your first installation.
- During the day, turn off all the lights in the room to see how much natural light comes in through the windows, and determine the best position for the Solatube Daylighting System. To light a specific area, place the system over the area, not in the center of the room. This will prevent the desired area from being shaded by tall objects in the room.
- Measure the distance from curb to diffuser level. If you don't have enough tubing, contact your Solatube International representative for additional tubing.
- Avoid roof locations shaded by trees, ridges and chimneys, or near water channels or valleys. Also avoid roof areas with obstructions such as fire sprinklers, HVAC equipment, gas, water or drain pipes, air ducts or flues and make sure that the roof is adequate to endure an installation without damaging its waterproofing properties or weakening the building structure.
- All adhesives and seals are recommended to be applied to a clean and dry surface at a minimum of 70°F (21°C) for maximum performance.
- For installations where high levels of soot or debris may be present it may be necessary to use foil tape to seal all joints and tube seams to prevent excess debris from entering the tubing.
- It is recommended to use foil tape to seal all joints and tube seams for installations in cold climates or where humid conditions may be present in order to prevent warm or moist air from entering the tubing.
- Uninstalled product that is stored and exposed to excessive heat and or humidity can experience damage. Store product prior to installation in a cool dry place.



## Daylight Dimmer Installation Tips

**Please follow all local municipal and building code requirements prior to making electrical connections.**

- General Circuit Limitations: (2) Solatube Daylight Dimmers per 20VA transformer and (8) Solatube Daylight Dimmers per 96VA transformer.
- Max cable length between units 40 ft (12.19 m), aggregate control cable length not to exceed 2,110 ft (643 m).
- Ensure Placement of Daylight Dimmer Junction Box is uniform for all units in installation for ease of wire connection and for best aesthetics.
- For ease of wire connection to terminal blocks do not strip wire more than 3/16".
- Good ground connection is critical to proper operation of this system. Ensure that ground connections are properly and securely bonded to terminal blocks to reduce risk of noise and ensure proper functionality of system.
- Segregate power and signal cables entering into junction box to avoid crossover noise. Also, cross the control lines and the power lines perpendicular inside junction box to avoid noise. (See diagram on page 8, 9, and 10)
- Avoid bumping capacitors on PCB (Printed Circuit Board) to reduce risk of damage.
  - If capacitors are bumped and become loose, replace entire junction box as improper functionality of Daylight Dimmers is highly probable.
- When connecting to 0-10V Current Sinking Lighting Controllers, Keep resistor in Aux CNTR Terminal on first unit in control circuit series. Remove resistor from all subsequent units.
- When connecting to 0-10V Current Sourcing Lighting Controllers, Remove resistor in Aux CNTR Terminal on all units.
- When connecting to Open/Close operation to standard wall switch remove resistor from Aux CNTR Terminal on all units.
- When connecting to dimming wall control remove resistor from Aux CNTR Terminal on all units.



## Troubleshooting

Issue	Possible Causes	Suggestions
Daylight Dimmer(s) do not open or close	Wire/Connection Issue	Check that line voltage Circuit is ON.
		Check line voltage wire connections to Lighting Controller and Transformer
		Check low voltage power and control wire connections to terminal blocks.
Daylight Dimmer(s) do not open or close completely	Lighting Control System Trim	Trim is not correctly set on lighting control wall switch. See control manufacturer's specification for adjusting trim.
	Obstruction	Remove Dome & Diffuser to inspect for obstruction inside tube preventing dampers from opening or closing completely. Remove all obstructions.
	Wire/Connection Issue	Check wire connections to ensure all line, neutral, ground and load cables are connected correctly (verify Load Connection is necessary for application).
One or more Daylight Dimmer(s) in series oscillate without change in lighting control command	Wiring/Connection Issue	Ensure that transformer is connected directly to Supply Line. Do not connect transformer to Lighting Controller load circuit relay .
		Review and test the first functioning Daylight Dimmer in series prior to the oscillating unit. Check all wires are properly connected. Ensure all strands are in terminal blocks; no strands are loose or protruding from terminal connection. Once finished move on to the next Daylight Dimmer in series and repeat process. Test each Daylight Dimmer before moving on.
	Wiring-Grounding Connection	Check wire connections at controller to ensure all line, neutral, ground and load are connected correctly.
	Damaged component on PCB	Check ground connections at transformer Junction Box and at ground terminals at each successive unit. Using Mutimeter, check for AC Voltage between (+ & -) pins on CNTR IN and CNTR OUT terminals. If >0.05VAC, review Printed Circuit Board (PCB) to see whether any components have been compromised (during installation). If Capacitors or Terminal Blocks are loose or missing, replace entire J-Box.
Units make "humming" sound after moving from position A to position B.	Wiring-Grounding Connection	Make sure ground wire is attached to a known good earth ground.
		Check all board to board ground connections.
Last unit not as open as first unit or all units not at same position.	Wiring Connection & Cable Length	Make sure you have properly attached signal wires from unit to unit. Check In & Out assignments and polarity.
		Make sure you have not exceeded maximum distance from either, unit to unit, or source to unit.
Units closest to power transformer open faster than units farther from transformer.	Transformer Quantity	May have exceeded the maximum number of units recommended for Daylight Dimmer Model or Transformer VA Rating.

For the most current Installation Instructions, please visit [www.solatube.com/instructions](http://www.solatube.com/instructions)

Note: Follow Steps 2 Through 4 in Main Set of SkyVault Installation Instructions (P/N: 949990) Prior to Installing the Daylight Dimmer.

# 1

## Assemble Transition Tubes

Align pre-punched holes and install rivets.

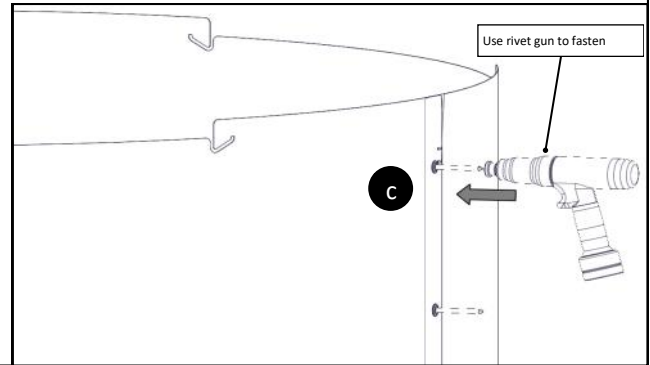
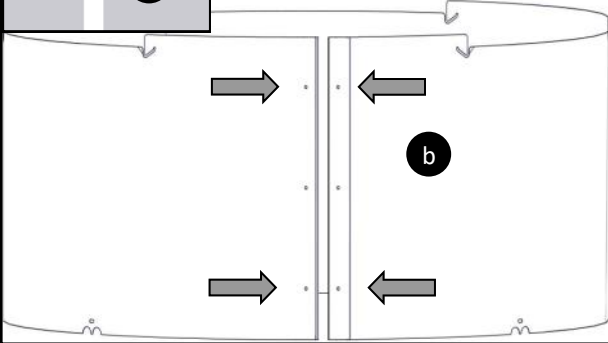
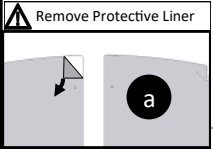

# 2

## Install Transition Tube

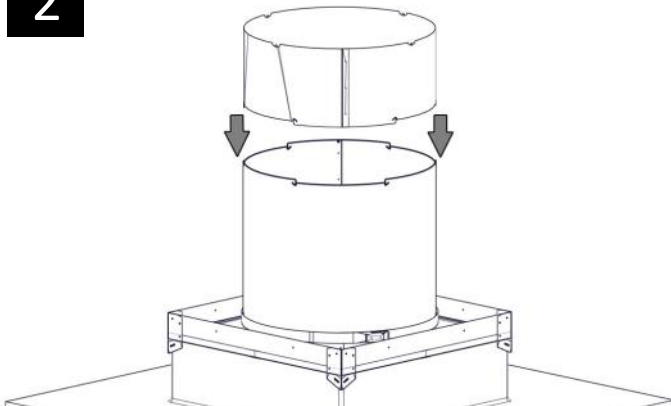

Refer to step 3 in the main set of M74 DS instructions (949990) for tab lock connection.

# 3

## Assemble Tube Belt and Install

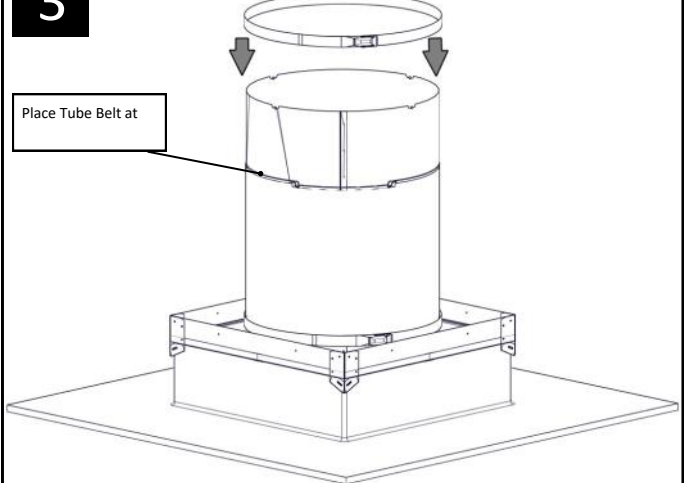

# 4

## Install Daylight Dimmer Ring

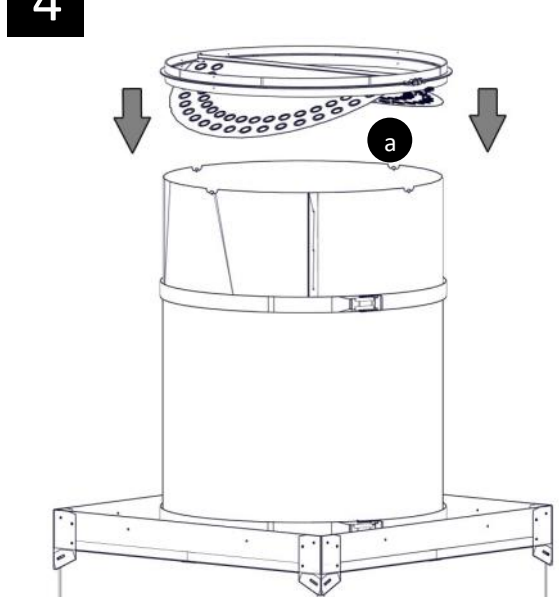

Align tabs on Daylight Dimmer Ring with notches on Transition Tube.

NOTE: Daylight Dimmer fins have been removed to show detail.

NOTE: Transition Tube fits inside of Daylight Dimmer Ring.

NOTE: Use care to ensure location of Daylight Dimmer Junction Box will be uniform for all units installed.

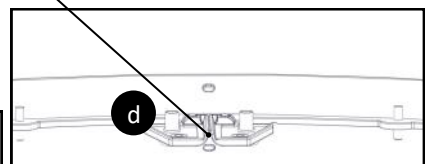
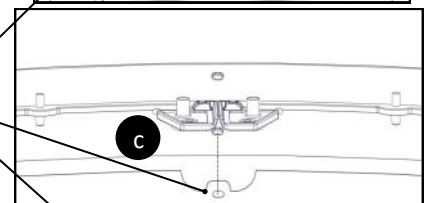
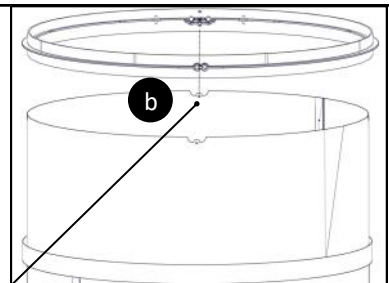

For the most current Installation Instructions, please visit [www.solatube.com/instructions](http://www.solatube.com/instructions)  
 Solatube International, Inc. | 2210 Oak Ridge Way | Vista, CA 92081-8341 | [www.solatube.com](http://www.solatube.com) | T: 888.SOLATUBE

**5 Install Transition Tube to Daylight Dimmer Ring**  
Align tabs on Daylight Dimmer Ring with notches on Transition Tube.

Align seams on Transition Tubes to ensure Tab Locks remain aligned

Note:  
If daylight is desired in space prior to electrical connections, remove Installation Retainer Clip and allow Daylight Dimmer dampers to open. Then replace Installation Retainer Clip.

**6 Fasten Transition Tubes to Daylight Dimmer Ring**

Use rivet gun to fasten 2 rivets (4 total) to each side of Daylight Dimmer Ring.

**7 Apply Foil Tape**  
Secure Daylight Dimmer Ring to Transition Tubes using foil tape.

Foil Tape

**8 Remove and Rotate Completed Assembly**

**9 Install Assembled Unit into Roof Curb.**

**10 Continue assembly from below.**

For the most current Installation Instructions, please visit [www.solatube.com/instructions](http://www.solatube.com/instructions)

# The Following Instructions Should Only Be Performed By A Licensed Electrician

Note: Please follow all local municipal and building code requirements prior to making electrical connections.

## 11 Determine Appropriate Transformer

Maximum Daylight Dimmer Unit QTY / Transformer

Transformer	20VA	96VA
Max QTY	2	8

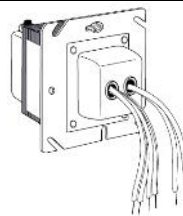
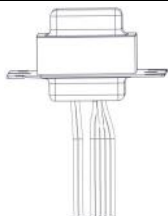

## 11 Option 1 Install 24VAC, Rated 20VA Transformer and Connect Power (Max 2 Daylight Dimmers)

Connect wires with appropriate voltage connection.  
Junction Box Provided by

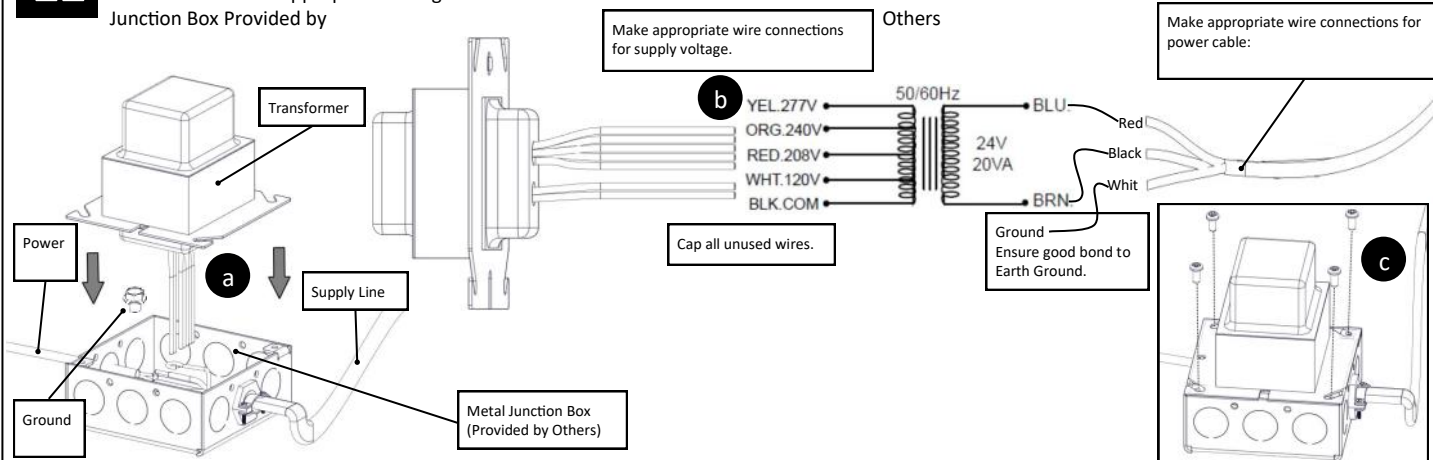

## 11 Option 2 Install 24VAC, Rated 96VA Transformer and Connect Power (Max 8 Daylight Dimmers)

Connect wires with appropriate voltage connection.  
Junction Box Provided by

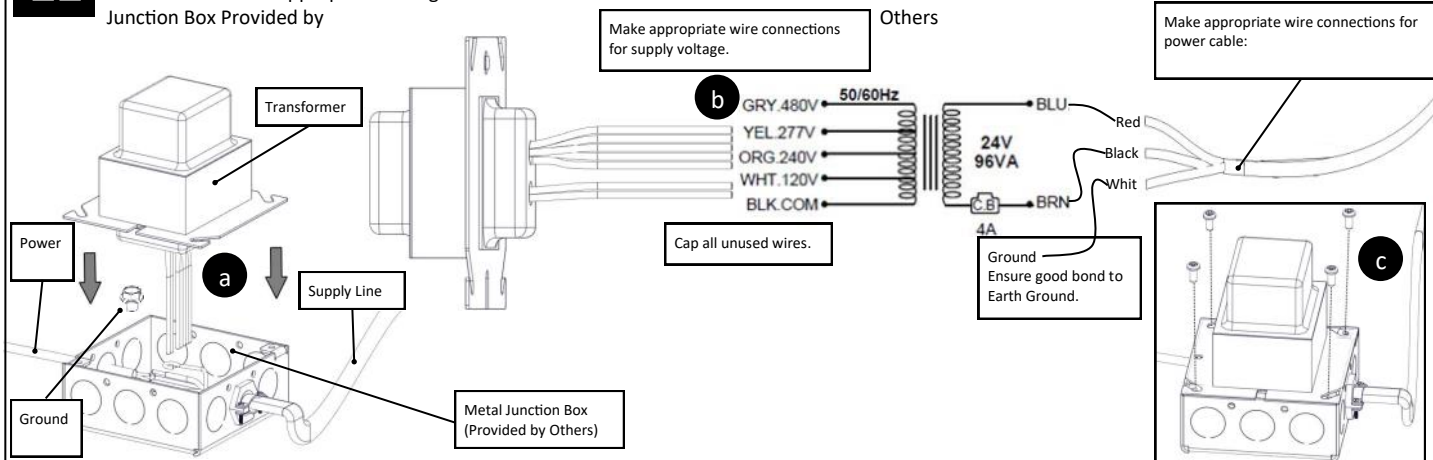

Note: Installation shown with Solatube supplied Transformer. If sourcing transformer from others please follow wiring instructions provided from transformer manufacturer.



# The Following Instructions Should Only Be Performed By A Licensed Electrician

Note: Please follow all local municipal and building code requirements prior to making electrical connections.

## 12 Remove Junction Box Cover

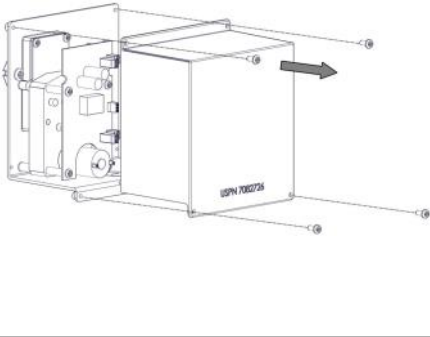

## 13 Install Spacer on back side of Daylight Dimmer Junction Box

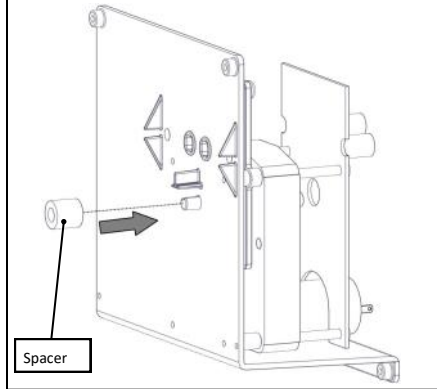

## 14 Remove Retainer Clip

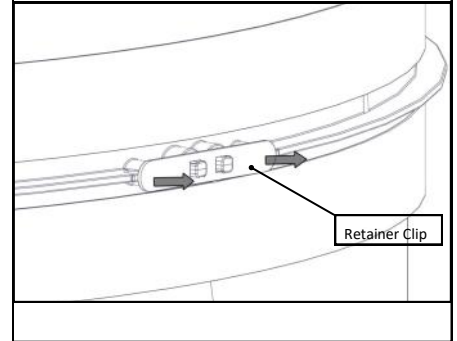

## 15 Install Junction Box to Daylight Dimmer Ring

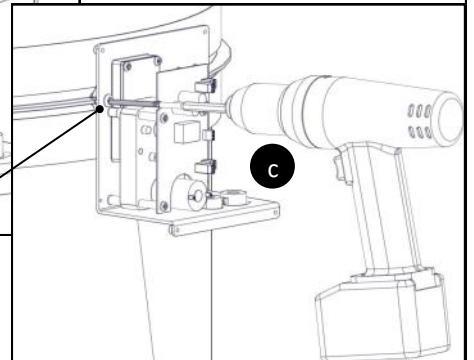
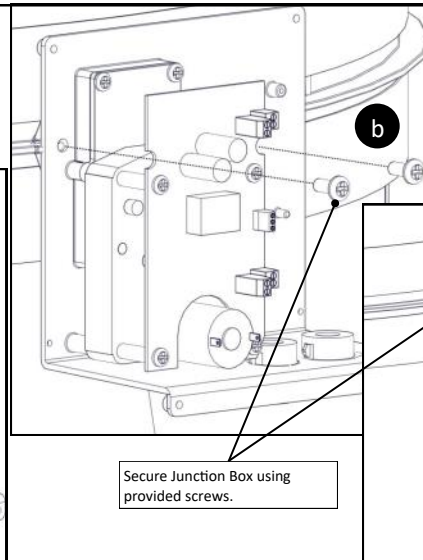
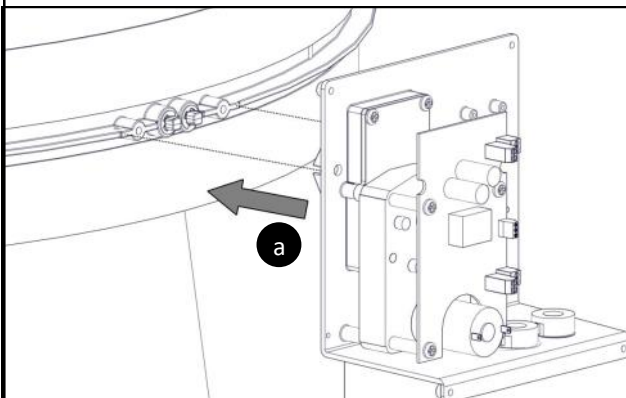

Secure Junction Box using provided screws.



# The Following Instructions Should Only Be Performed By A Licensed Electrician

Note: Please follow all local municipal and building code requirements prior to making electrical connections.

General Circuit Limitations: (8) Solatube Daylight Dimmers per Transformer, Max Cable Length between Units 40 ft (12.19 m), Aggregate Control Cable Length no to exceed 2,110 ft (643 m).

## 16

### Option 1: Wire Connection for use with 0-10V Current Sinking or Sourcing Lighting Controller

0-10V Dimming Control Panel Provided by Others

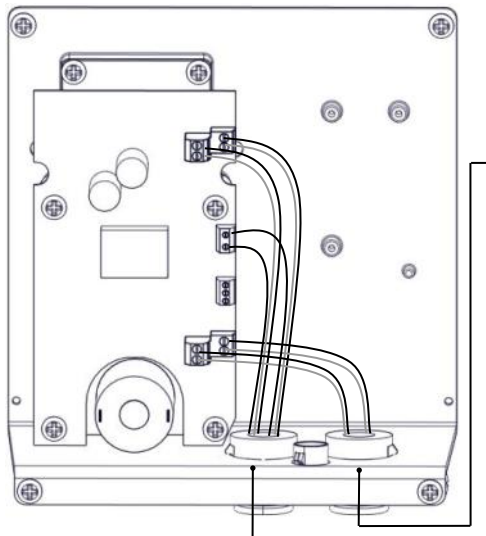
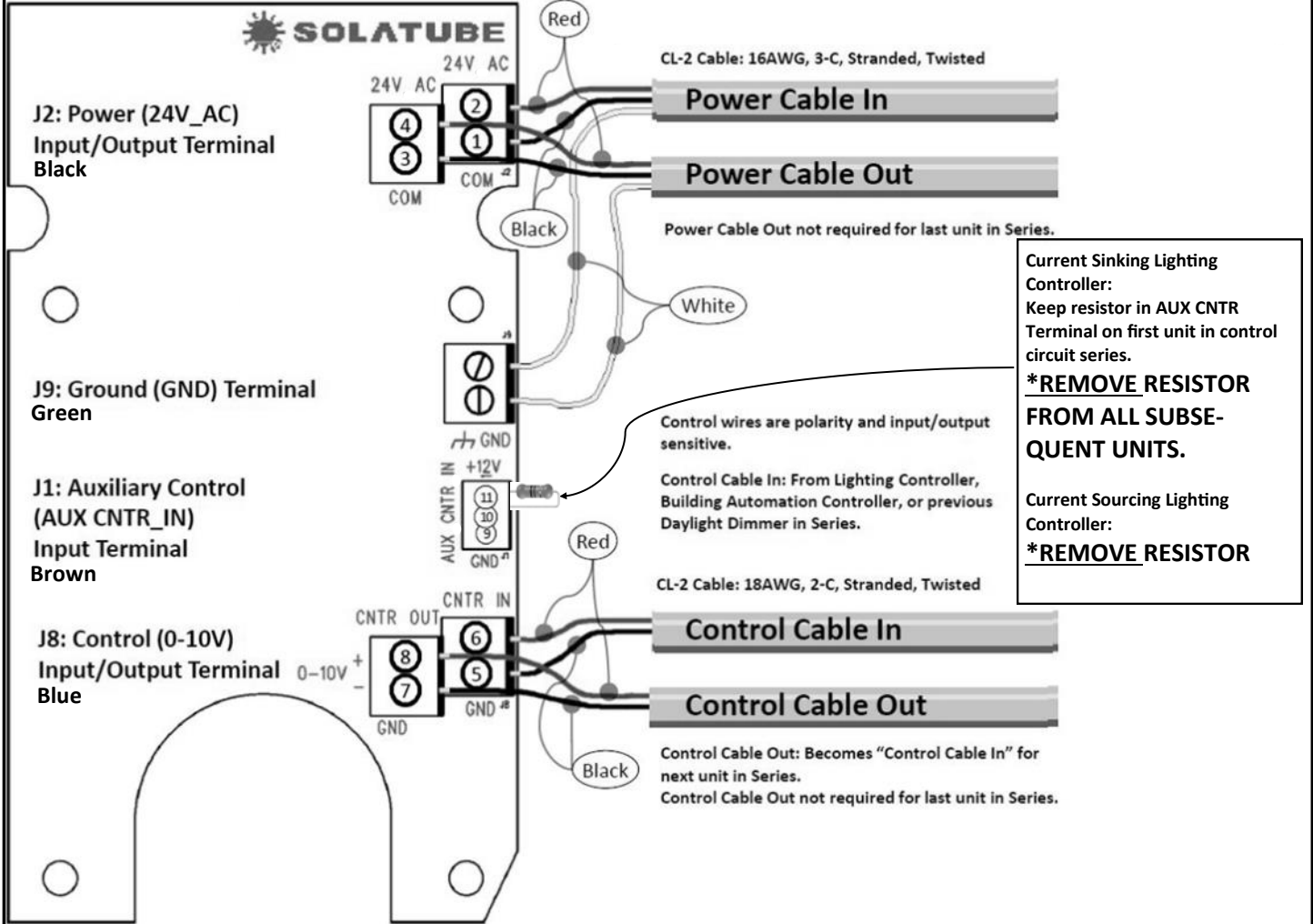

For best connections and to avoid noise, segregate power and signal cable, and cross Control and Power lines

Run Control lines here

Run Supply lines here

**NOTE:** For best application and ease of installation strip wires Min. 3/16 in (4.8 mm) /Max 1/4 in (6.4 mm). Ensure all strands enter housing to correct terminal.

# The Following Instructions Should Only Be Performed By A Licensed Electrician

Note: Please follow all local municipal and building code requirements prior to making electrical connections.

General Circuit Limitations: (8) Solatube Daylight Dimmers per Transformer, Max Cable Length between Units 40 ft (12.19 m), Aggregate Control Cable Length no to exceed 2,110 ft (643 m).

16

## Option 2: Wire Connection for Open/ Close Operation Only Connecting to Standard Wall Switch Wall Switch Provided by Others.

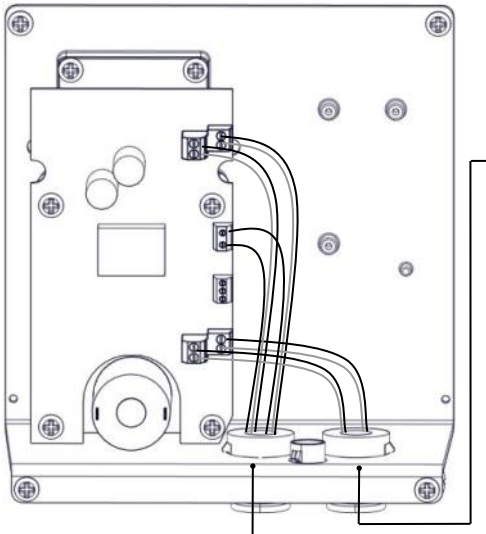
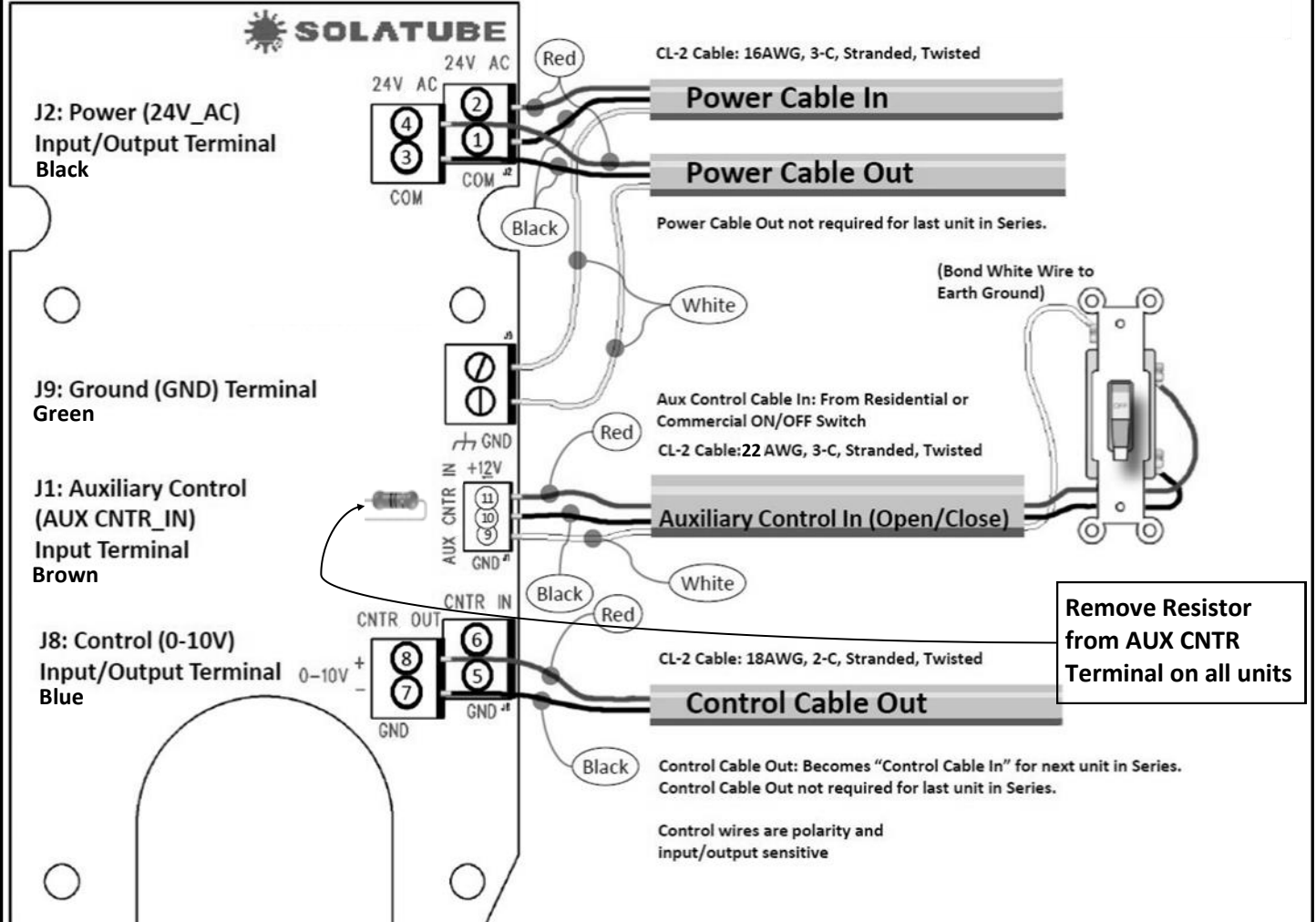

For best connections and to avoid noise, segregate power and signal cable, and cross Control and Power lines

Run Control lines here

Run Supply lines here

**NOTE:** For best application and ease of installation strip wires Min. 3/16 in (4.8 mm) /Max 1/4 in (6.4 mm). Ensure all strands enter housing to correct terminal.

10

For the most current Installation Instructions, please visit [www.solatube.com/instructions](http://www.solatube.com/instructions)  
Solatube International, Inc. | 2210 Oak Ridge Way | Vista, CA 92081-8341 | [www.solatube.com](http://www.solatube.com) | T: 888.SOLATUBE

**17**

**Replace Junction Box Cover**

Secure Daylight Dimmer Junction Box Cover with 4 provided screw fasteners.

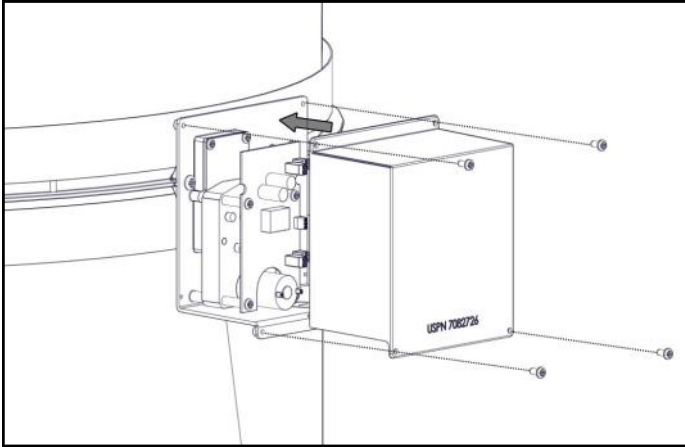

**18**

**Return to Main Set of SkyVault Installation Instructions (P/N: 949990) for Additional Tube, Diffuser or Amplifier Attachment**

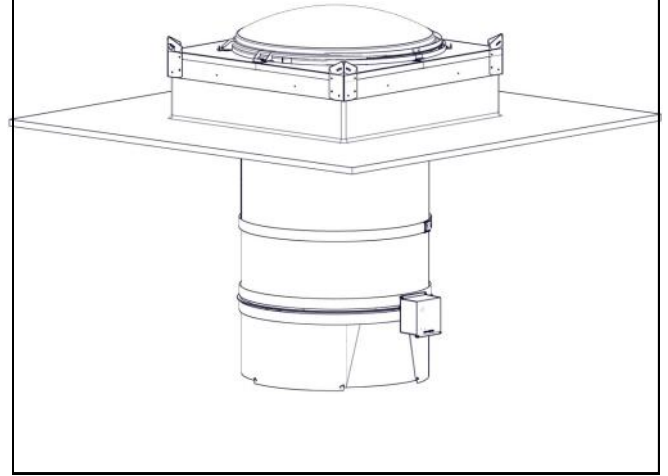

## Solatube Daylight Dimmer Typical Single Controller Wire Diagram

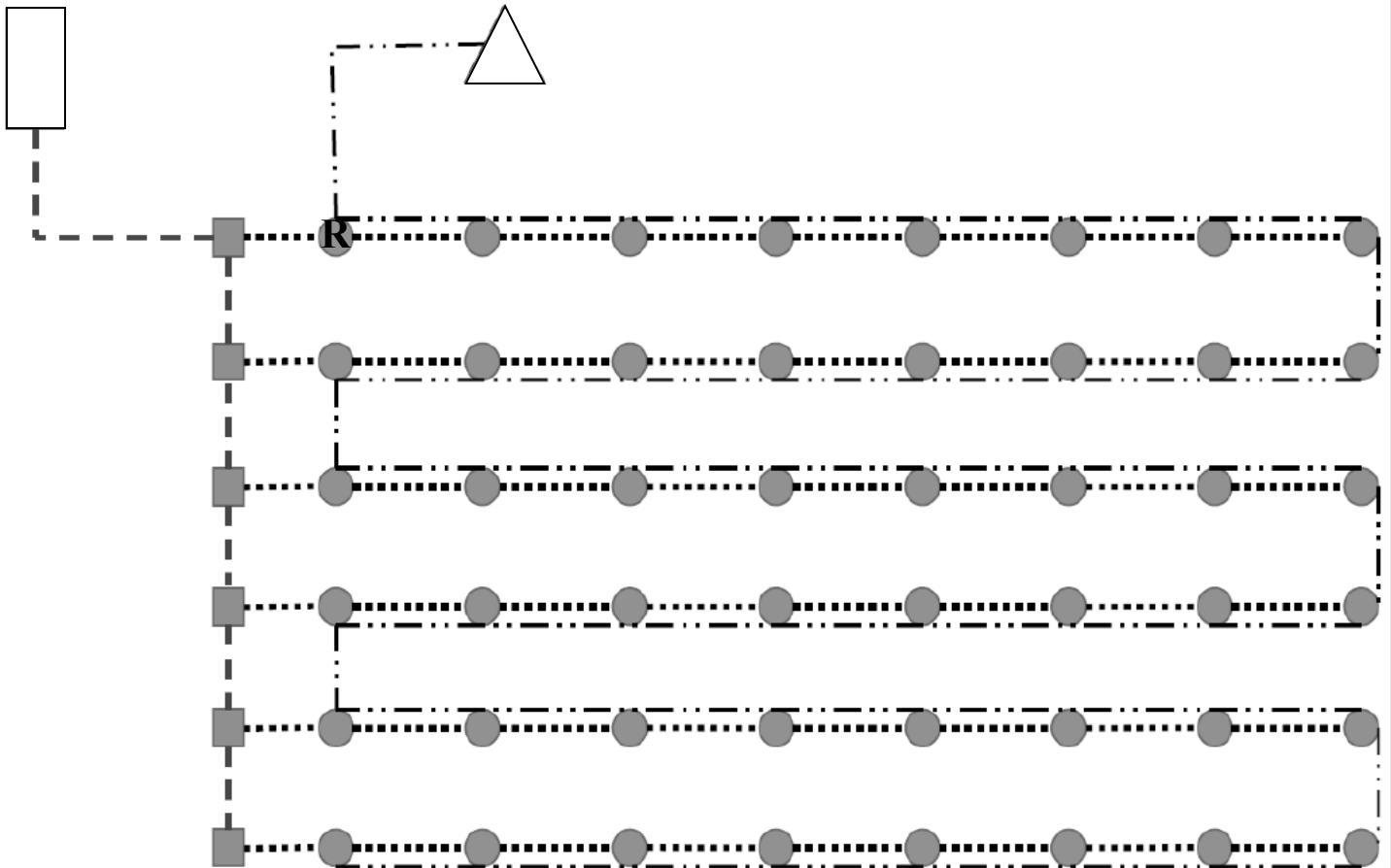
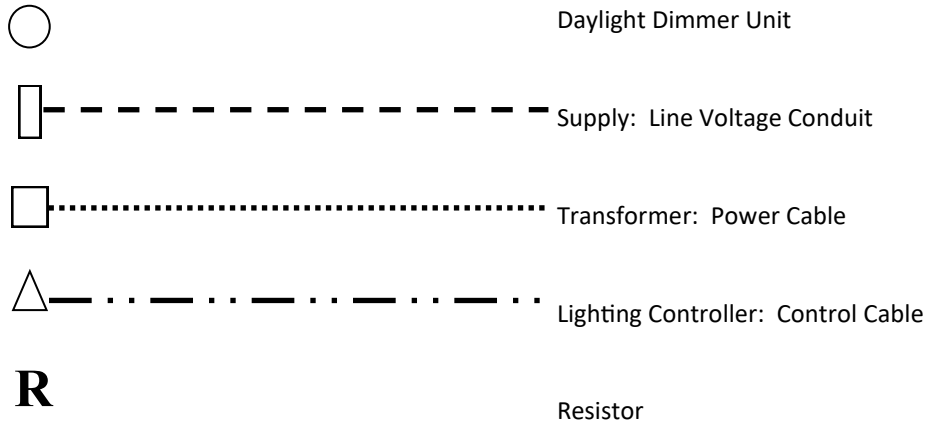

For the most current Installation Instructions, please visit [www.solatube.com/instructions](http://www.solatube.com/instructions)

## Solatube Daylight Dimmer Typical Two (2) Controller Wire Diagram

